



V. Guldmann A/S
Graham Bells Vej 21-23A
DK-8200 Aarhus N
Tel. +45 8741 3100
Fax +45 8741 3131
info@guldmann.com
www.guldmann.com

Horizontal lifting support with weight adjustment, 375 kg

Technical specifications

Functions

Lifting capacity, max. : 375 kg
Suspension points : 8

Weight and Materials

Total weight : 11,6 kg
Lifting hanger : Powder coated steel, RAL 9016

Measurements

A : 1054 mm
B : 110 mm
C : 1395 mm
D : 510 mm
E : 500 mm
F : 525 mm
G : 569 mm
H : 710 mm
I : 212 mm

Accessories/ Miscellaneous

Lifting sling : See brochure

Labelling

The product is manufactured in compliance with the Council Directive 93/42/EEC of June 14th 1993, including amendments, as medical device class 1.

Item Number/Model

28456 : Horizontal lifting support with weight adjustment

Classification

according to ISO 9999 : 12 36 03

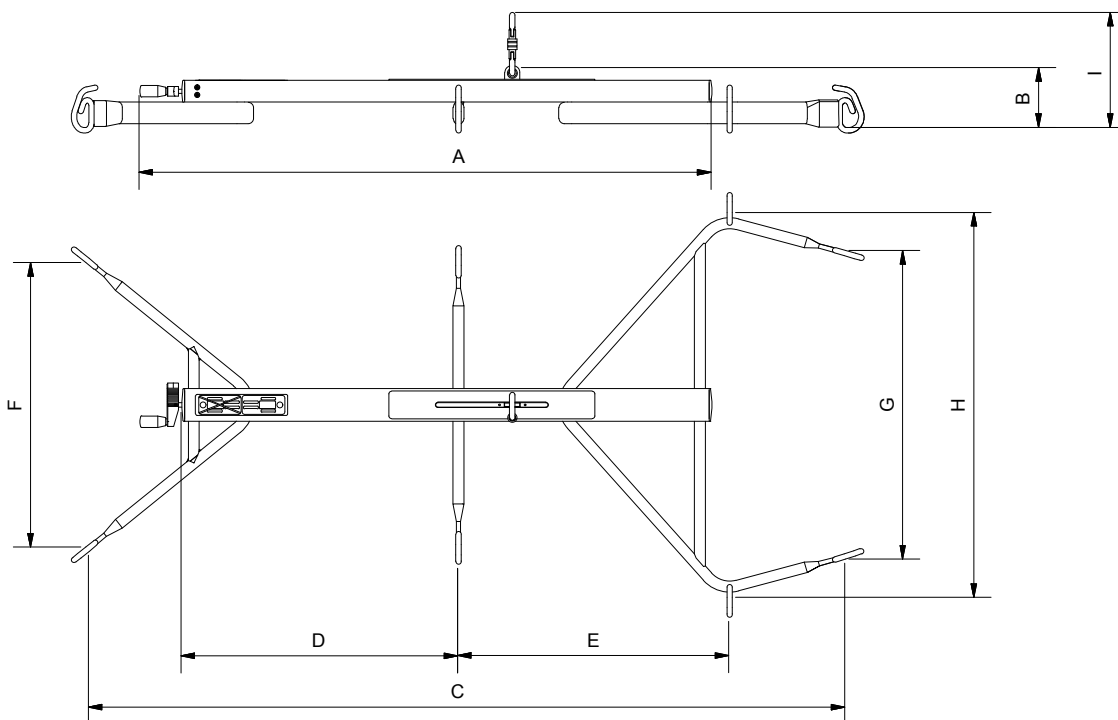

Time to care

Guldmann™