



www.evocare.com.au

Phone:07 33558000 Fax:07 33555043

GBPontus free-standing B-rail systems

Vers. 1.00



Guldmann®

Pontus, free-standing rail systems

Item numbers:

550371 (single rail system)

550372 (room-covering rail system)

1.00	Purpose and use	3
1.01	Manufacturer	3
1.02	Purpose and use	3
1.03	Important/Precautions	3
1.04	Lifters made by other manufacturers	3
1.05	Unpacking and Preparation	3
1.06	Mounting prior to setting up	4
1.07	Installing Pontus – single rail system	6
1.08	Installing Pontus – room-covering rail system	6
<hr/>		
2.00	Description of functions	9
2.01	Operation	9
2.02	Mounting charging liner connector	9
<hr/>		
3.00	Dismounting and transport	10
3.01	Dismounting Pontus	10
3.02	How should Pontus be transported?	10
3.03	How should Pontus be packed during transport?	10
<hr/>		
4.00	Maintenance and storage	10
4.01	Cleaning	10
4.02	Storage	10
4.03	How is corrosion prevented/avoided?	10
4.04	What maintenance should the owner carry out?	10
<hr/>		
5.00	Service and life span	11
5.01	Life span	11
5.02	Troubleshooting	11
<hr/>		
6.00	Technical specifications	11

1.00 Purpose and use

1.01 Manufacturer

V. Guldmann A/S
Graham Bells Vej 21-23A
DK-8200 Århus N
Tel. + 45 8741 3100
Fax + 45 8741 3131

1.02 Purpose and use**Purpose**

Pontus free-standing rail systems – the single rail system, item no. 550371 and the room-covering system, item no. 550372 – are two non-stationary systems. The Pontus rail systems are employed with the Guldmann hoist. They can be installed practically anywhere and require no mounting on walls, ceilings or floors.

The Pontus systems will satisfy the requirements for transferring elderly and disabled people in places like hospitals, rest homes, institutions and private homes.

1.03 Important/precautions

- Read the entire user's manual prior to assembly and prior to the Pontus system being put into operation.
 - Pontus should be installed and taken down by no less than two persons.
 - The Pontus' maximum load of 250 kg must **not** be exceeded.
 - In the case of damages to the Pontus system, discontinue use.
 - Pontus is purpose-built for lifting people.
 - Pontus should be installed on a plane surface.
 - Pontus must not be used for any other purpose than that stated in the user's manual; that is, neither as a playground or a swinging device.
-

1.04 Lifters made by other manufacturers

Only hoists from Guldmann may be applied in the Pontus system. Guldmann is not liable for defects or accidents caused by the application of hoists/lifting modules made by other manufacturers.

1.05 Unpacking and preparation**Visual inspection of the free-standing rail system:**

If the packaging is damaged on receipt, the components of Pontus should be carefully checked for noticeable imperfections, defects or flaws.

If damage is suspected, Pontus should not be assembled/employed until the Pontus system has been approved by qualified service staff or the Guldmann Service Team.

Pontus single B-rail system consists of:

Pos.

1. Feet (2 pcs)
2. Support posts, square shaped (2 pcs)
3. Top brackets (2 pcs)
4. B-rail (1 pcs)
5. End stops (2 pcs) (not illustrated)

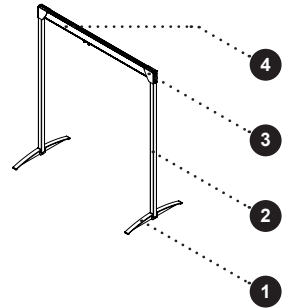

Pontus room-covering B-rail system consists of:

Pos.

1. Support posts, square shaped (4 pcs)
2. Corner brackets (4 pcs)
3. B-rails (4 pcs)
4. Traverse rail (1 pcs)
5. End stops (6 pcs) (not illustrated)
6. Trolleys for traverse rail (2 pcs) (not illustrated)
7. Plastic endcaps (4 pcs)

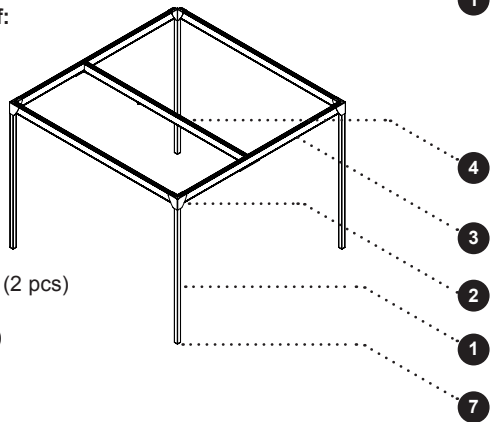

1.06

Mounting prior to installing

Pontus single rail system

1. Mounting the top brackets etc.

The top bracket (pos. 1) should be mounted to the leg (pos. 2) first. Make sure that all screws (pos. x and y) are loosened so the bracket easily slides over the leg. First tighten the 3 screws/nuts (pos. x) on the back of the bracket. Then tighten the 4 pointed screws (pos. y).

Place the mounting plate (pos. 3) on the top bracket and put two M10 lock nuts (pos. 4) loosely onto the bracket.

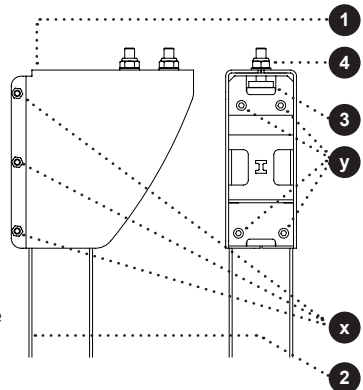

2. Mounting the feet

Mount the feet (pos. 1) in pairs by means of a transverse bolt (pos. 2). The borings on the transverse bolt must face the pointed screws.

Position the support posts (pos.3) in the grooves (pos.4) of the feet. The top bracket must be positioned perpendicular til the feet.

Join the feet and the support posts by tightening the pointed screws on the sides of the feet with a 5 mm Allen key (pos.5).

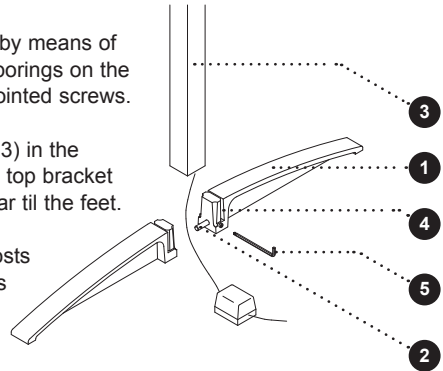

3. Connecting the charging liner connector

Insert the output wire from the transformer through the cut-out section in the foot (see figure above) and pull it up through the support post and out of the triangular hole at the top of the bracket. Then insert the wire back into the bracket through the nearest hole.

Mount the charging liner connector (pos. x) on the wire by clamping the two stripped ends under the cylindrical pins (one under each) pressed into the black ferrule.

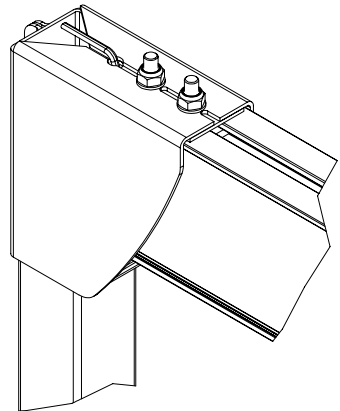
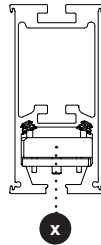

Installing the system

Support the B-rail (pos. 1) so the end stops (pos. 2) and the trolley/hoist (pos. 3) can be placed in the rail.

Positioning the trolley/hoist in the middle of the rail by means of the end stops.

The rubber tips of the end stops should be facing towards the trolley.

Push the B-rail towards the bottom of the top bracket on the post so the mounting plate (pos. 5) slides into the upper track of the B-rail. Tighten the M10 locking nuts (pos.6) to a torque of 40 Nm with a 17 mm wrench.

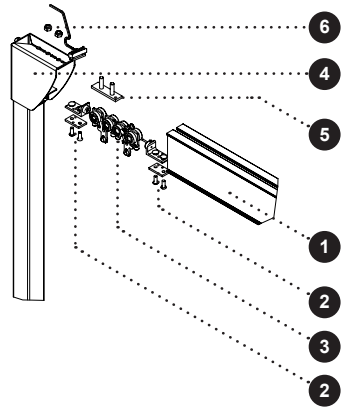

Follow the same procedure for the other top bracket.

Use a “Lasy boy” support if necessary.

Loosen the end stops and tighten these as close to the top bracket as required.

Insert the connector at an angle (approximately 7-12°) in the end of the rail (between the topbracket and endstop), and fix this into place by tightening the pointed screw through the track opening of the rail so the pins are pressed against the copper tracks at the bottom of the rail.

Installing Pontus – room-covering rail system

Guldmann recommends that the Pontus room-covering rail system is installed and taken down by two qualified installers.

Mounting aids:

Use two “Lasy boys” supports when installing the Pontus room-covering rail system.

Make sure that the floor is protected with thick cardboard or a cloth while setting up the room-covering rail system.

Premounting the legs:

All support posts are fitted with plastic endcaps (pos. 3, page 7).

1. Mounting the top brackets

The top bracket (pos. 2) should be mounted to the leg (pos. 1) first. Make sure that all screws for fixing the bracket are loosened so the bracket easily slides over the leg. Tighten the 8 pointed screws. Place the mounting plate (pos. 4) on the top bracket with M10 lock nuts on. Mount all four legs with top brackets as stated.

2. Mounting trolleys for traverse rail in two parallel rails

Place the B-rail on its side and mount an end stop (pos. 5), a traverse trolley (pos. 6) and an end stop in the above order. The rubber tips of the end stops should be facing towards the traverse trolley. Positioning the trolley in the middle of the rails. The mounting plate at the traverse trolley must face inwards in the system. Remember to install the Power pickup (pos. 7) on one of the trolleys.

Please note!

The longest B-rail (3 m) is the traverse rail.

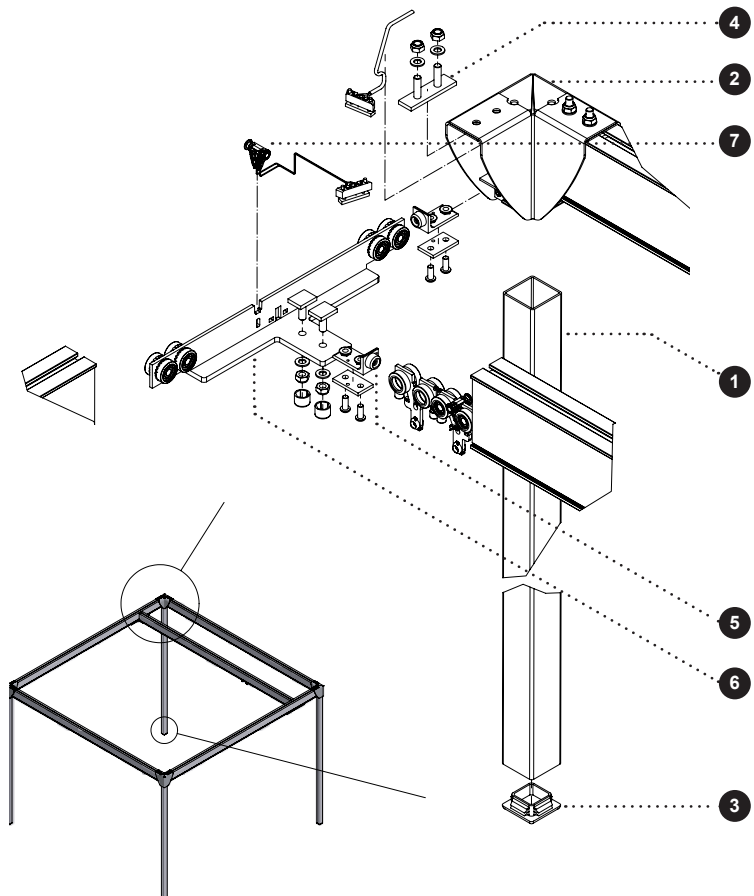

1. Room-covering rail system

If required, the output wire from the transformer can be led up through the leg to the top bracket. Make an angular cut in the plastic endcap with a fine tooth saw (fig. 1). Make sure that the edge of the support post is not resting on the wire. Pull the wire through the top bracket's wedge-shaped opening and insert it back into the bracket through the nearest hole (fig. 2). Then mount the charging liner connector as described in the preceding section.

In order to convey the charging current from the parallel rail to the traverse rail, mount the Power pickup (see pos. 7 on page 7) on the traverse trolley and mount the wire to the charging liner connector.

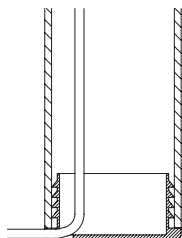

Fig. 1

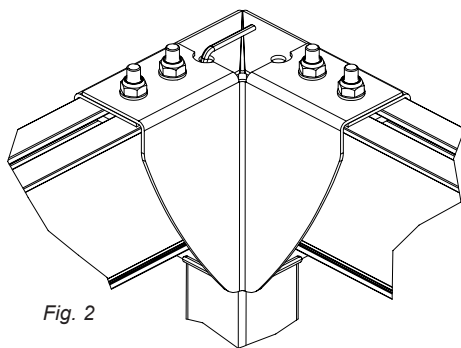

Fig. 2

2. Installing the system

Place one of the two parallel rails on the “lazy boy” supports adjusted to the approximately final height.

Insert the top bracket with leg into the end of the rail, making sure to push the rail as far into the bracket as possible while checking that the mounting plate is positioned correctly in the upper track of the rail. Remember to place the top brackets so that they are facing the same way as the mounting plate at the traverse trolley. Tighten the M10 lock nuts to a torque of 40 Nm with a 17 mm wrench.

Continue installing a rail attached to a top bracket with leg, without a trolley perpendicular to the system resting on the “lazy boys” supports. Use the supports to install the next rail; a rail with a traverse trolley for attached to a bracket with leg. Install the last rail which is a rail without a trolley.

3. Inspection

Check that the rails are pushed as far into the brackets as possible and that the rails with traverse trolleys are parallel. It can be an advantage to take the diagonal measurement to check the rails are parallel.

Check that alle lock nuts are tightened securely.

4. Installing the traverse rail

Place the traverse rail, the last B-rail, on its side and mount an end stop, a trolley/hoist, and an end stop in the above order.

The rubber tips of the end stops must face towards the trolley/hoist and be positioned in the middle of the rail. Install the traverse rail at the mountings plates at the traverse trolleys.

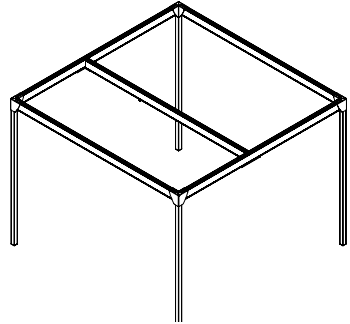

5. Inspection

Check that the traverse rail runs freely between the parallel rails.

The traverse rail should be at an equal distance to the parallel rail at both ends after mounting.

6. Adjusting the end stops on the parallel rails

Loosen the four end stops on the parallel rails, position them correctly and tighten them at the top brackets. Run the traverse rail towards the end stops at one end and adjust the traverse rail so that the two trolleys touch the end stops simultaneously. Follow the same procedure for the opposite end.

7. Adjusting the end stops in the traverse rail

Loosen the two end stops in the traverse rail (pos. 1). Position the end stops in the traverse rail (one at each end) and tighten them.

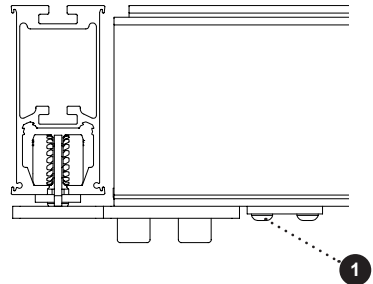

8. Inspection

Check that all screws and nuts are tightened correctly and that the rail system is stable before putting the system into operation.

2.00 Description of functions

2.01 Operation

Transport/running in the rail system

Depends on the selected hoist/lifting module.

2.02 Mounting the charging liner connector

See user's manual of the selected hoist/lifting module.

3.00 Dismounting and transportation

3.01 Dismounting Pontus, the free-standing rail system

Dismount Pontus in the reverse order of that when mounting, see section 1.07 and 1.08.

It might be necessary to loosen the top bracket from the support posts by pushing the rail upwards in order to separate them.

Important:

Before taking down the Pontus rail system, the hoist and travers trolleys must be secured by means of the end stops.

3.02 How to transport the Pontus rail system?

At a minimum, the Pontus rail system should be taken apart so that the legs are separated from the B-rails with regard to transporting and storage, see section 3.01.

3.03 How should Pontus be packed during transport?

Guldmann recommends that Pontus, after being dismounted, is always transported in its original packaging.

4.00 Maintenance and storage

4.01 Cleaning

Clean Pontus with a damp cloth using ordinary household detergents. Chemicals or an autoclave must not be used when cleaning Pontus.

4.02 Storage

Pontus should be stored in a dry room in which the humidity of the atmosphere does not exceed 70% which is why Pontus must not be stored in bathrooms or the like.

4.03 How is corrosion prevented/avoided?

The Pontus room-covering system should not be stored/kept in damp rooms for a long period of time. The water vapour can affect the trolleys in such a way that the bearings may corrode/rust.

4.04 What maintenance should the owner carry out?

Check regularly that the system is stable and retighten when necessary.

5.00 Service and life span

5.01 Life span

The estimated life span of the free-standing rail system is 15 years as the system is regarded as one unit. The estimated life span is, provided that the yearly safety/service inspection is observed.
Spare parts drawings can be obtained from the manufacturer or supplier.

5.02 Troubleshooting**1. The system is not stable**

- Check that the feet have been mounted correctly and that the support post been pressed home?
- Check that the top brackets is tightened?
- Check that the top brackets have been positioned correctly?
- Check the top brackets for defect or deformities?
- Check that the nuts which secure the rail to the brackets are tightened?

If the result of the above checks is satisfactory and the fault has not been detected, contact the distributor or the manufacturer.

6.00 Technical specifications**Pontus single rail system**

Dimensions (HxW) 2400 x 2690 mm
Maximum lifting capacity 250 kg
Lifting interval 2000 mm

Total weight without lifter

Single rail system. 38,0 kg
Legs 9,0 kg
MAXI rail 20,0 kg

Pontus room-covering rail system

Dimensions (HxWxD). 2400 x 3170 x 3170 mm
Maximum lifting capacity 250 kg
Lifting interval 2000 mm

Total weight without lifter

Room-covering rail system 123,0 kg
Legs (4 pcs) 18,0 kg
B-rails (4 pcs) incl. brackets 90,0 kg
Traverse rail incl. trolleys 23,0 kg

Pontus room-covering and single rail system, materials

Rails and legs Anodized aluminium
Feet and levers Powder varnished aluminium
Brackets: . . Powder varnished steel sheet Pontus, free-standing rail systems

EVOCARE AUSTRALIA PTY LIMITED

A.B.N. 98 078 566 604

Trading as **EVOCARE** and **L&M EQUIPMENT**

P.O. Box 1144, Stafford Qld. 4053

Ph: 07 3355 8000 Fax: 07 3355 5043

Website: <http://www.evocare.com.au>

E-Mail: sales@evocare.com.au

workshop@evocare.com.au

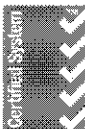

Quality
ISO 9001

Time to care

V. Guldmann A/S

Corporate Office:
Graham Bells Vej 21-23A
DK-8200 Århus N
Tlf. +45 8741 3100
Fax. +45 8741 3131
info@guldmann.com
www.guldmann.dk

Guldmann Inc.

5525 Johns Road
Suite 905
Tampa, FL 33634
Tel. 800 664 8834
Tel. 813 880 0619
Fax. 813 880 9558
info@guldmann.net
www.guldmann.net