

## User Instruction Manual Oxford® Presence

To avoid injury, read user manual prior to use.

Distributor

### **EVOCARE AUSTRALIA PTY LIMITED**

A.B.N. 98 078 566 604

Trading as **EVOCARE** and **L&M EQUIPMENT**

P.O. Box 1144, Stafford Qld. 4053

Ph: 07 3355 8000 Fax: 07 3355 5043

Website: <http://www.evocare.com.au>

Email: [sales@evocare.com.au](mailto:sales@evocare.com.au)

[workshop@evocare.com.au](mailto:workshop@evocare.com.au)

[warehouse@evocare.com.au](mailto:warehouse@evocare.com.au)

[accounts@evocare.com.au](mailto:accounts@evocare.com.au)

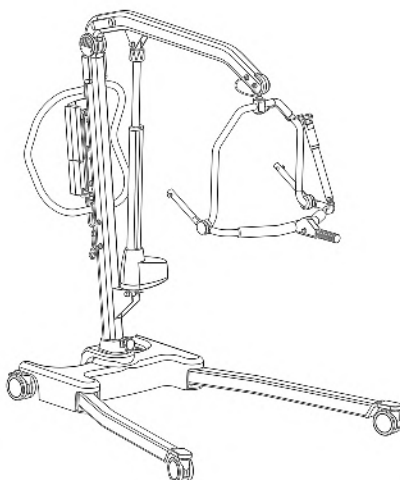
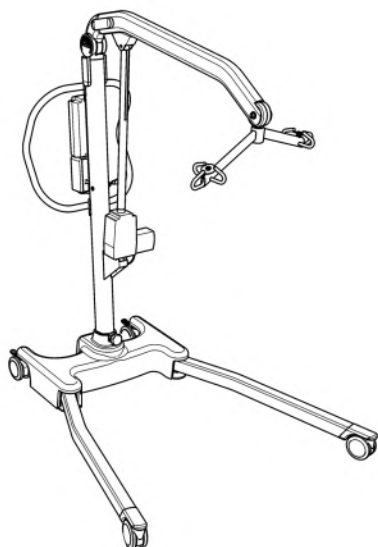

## Contents

1. The Oxford Presence Patient Lift.....	3
2. Introduction: About Your Lift .....	4
3. Assembly and Commissioning Instructions .....	5
4. Safety Precautions .....	11
5. Smart Monitor & Handset.....	13
6. Operating Instructions .....	18
7. Removal of Spreader Bar/Cradle Systems .....	21
8. Charging Instructions .....	23
9. Maintenance Schedule.....	25
10. Technical Specifications.....	27
11. Warranty.....	30

# 1. The Oxford Presence Patient Lift

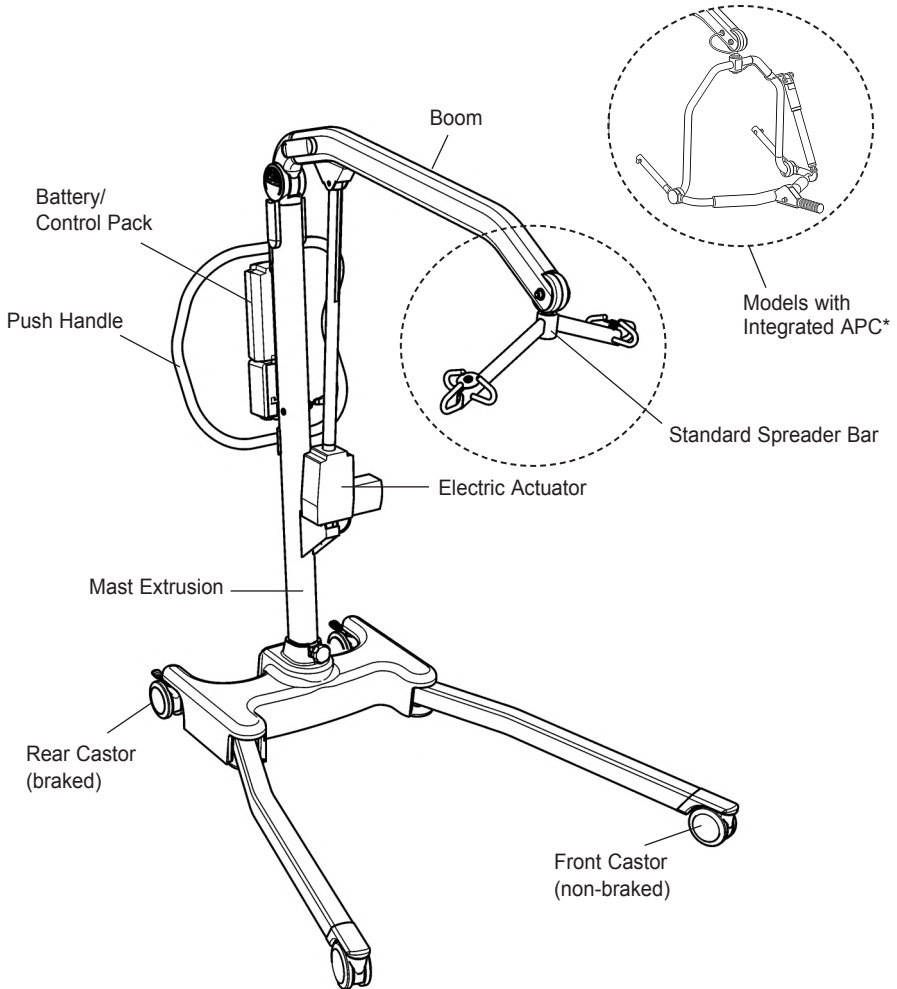

*\*The Integrated APC cannot be retro-fitted to standard Presence models. This must be specified at point of order. Alternatively, an optional, independently powered APC is available to order separately.*

## 2. Introduction: About Your Lift

Each Presence lift is fully assembled, load tested and certified before being packed/shipped.

The packing consists of a strong, purpose built carton that is used for both export and domestic markets to ensure the safe arrival of the lift. A number of documents are supplied in a wallet, and packed with each lift and should be kept safely for future reference.

- TEST CERTIFICATE
- USER MANUAL
- DEALER GUARANTEE CARD
- CUSTOMER SATISFACTION CARD
- PACKING CHECK LIST

The TEST CERTIFICATE is an important document and should be kept for reference purposes.

To properly maintain your lift please refer to the maintenance schedule included in this document. If you are at all unsure what your country's servicing requirements are, please check with your dealer and/or a local government agency.

**The CE mark:** The Oxford Presence carries the CE mark and complies with the following EC directives:



- Medical Device Directive (93/42/EEC)
- EMC Directive (89/336/EEC)
- Low Voltage Directive (73/23/EEC)

### Statement of Intended Use

The intended use of this lifting device is for the safe lifting and transfer of an individual from one resting surface to another (such as a bed to a wheelchair). Joerns Healthcare recommends that the transfer of a patient is fully risk assessed and conducted safely over a short distance only.

The Oxford Presence is suitable for patients in the SITTING, SITTING/RECUMBENT and RECUMBENT positions.

The Oxford Presence is an electrically operated patient lift, designed to support and promote safe patient handling and transfer for both the patient and carer.

The Oxford Presence lift is available in two variants; one which is fitted with a standard 6-point spreader bar and one that has an Integrated APC (4-point). The Oxford Presence lift which incorporates the 6-point spreader bar is also compatible with 4-point cradle options, available as after-market accessories. All configurations are designed to be used with the Oxford range of slings. The examples of slings suitable for use with this device are listed as follows:

- Oxford Quickfit
- Oxford Access
- Oxford Full Back
- Oxford Comfort
- Oxford Quickfit Deluxe
- Oxford Silkfit
- Oxford Long Seat

### Expected Service Life

Oxford Professional lifts are designed and tested for a minimum service life of ten (10) years, subject to the use and maintenance procedures stated in this manual. Use, other than in accordance with these instructions, may compromise service life.

## 3. Assembly and Commissioning Instructions

### Carton Contents

Place the carton in a clear working area and open carefully. The carton contains:

- OXFORD PRESENCE LIFT
- WALLET CONTAINING DOCUMENTS
- HAND CONTROL
- BATTERY PACK
- CHARGING LEAD
- DESK TOP CHARGER/STAND

### **▲ WARNING**

The Oxford Presence is heavy and will need to be lifted with care. You may need assistance to lift the Oxford Presence from the carton.

### Assembly Instructions

1. Remove all the parts from the carton and place on the floor, taking care to protect the finish from damage.

Place the chassis in a clear space and apply the rear bakes.

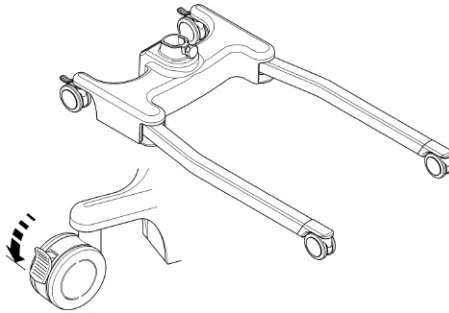

2. Fit the mast and boom assembly into the chassis socket

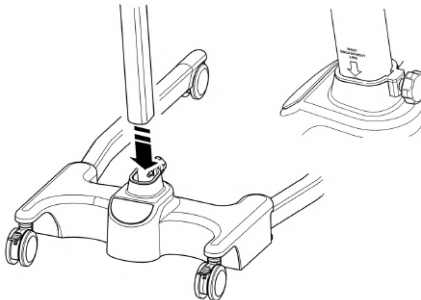

3. Tighten the mast assembly with the mast-locking device, which is located at the front of the chassis.

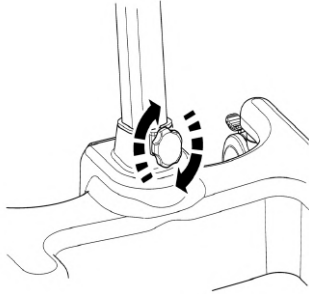

**⚠ WARNING**

Avoid trapping fingers. Keep fingers away from the end of the mast when inserting into the chassis socket. Full engagement of the mast is indicated by the label on the side of the mast. The electric leg operation will not function unless the mast is fully engaged.

4. Turn the locking knob until hand tight.
5. Line the handle assembly up to the rear of the mast, and attach using the fixings provided. The fixings and wrench needed to attached the handle are kept in the user instruction wallet for safe keeping.

**NOTE:** When attaching the handle to the mast be sure that all trailing wires are left outside the handle before fixing.

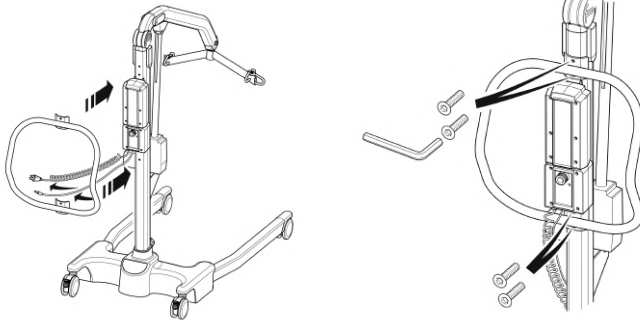

6. Fit power pack to the lift and make sure the latch holding the pack in place is fully engaged. "Click" in place.

## Initial Attachment of the Integrated APC

### FOLLOW THESE INSTRUCTIONS EXACTLY

The Integrated APC must be attached to the lift and connected electrically by a competent person before use. The Integrated APC is attached to the boom using the standard Presence quick release pin with the addition of the electrical connection which is made inside the boom.

### CONNECTION

#### To connect the cradle:

Lift the Integrated APC up towards the boom aperture.

Insert the pin sleeve through the plastic end cap and to support the Integrated APC.

Once aligned in the boom aperture, reinsert the quick release pin fully into the sleeve until it locks into position. **YOU MUST CHECK THAT THE PIN IS SECURELY FITTED.**

To do this, press your finger into the barbed end. If the pin remains stationary the lift is safe to use.

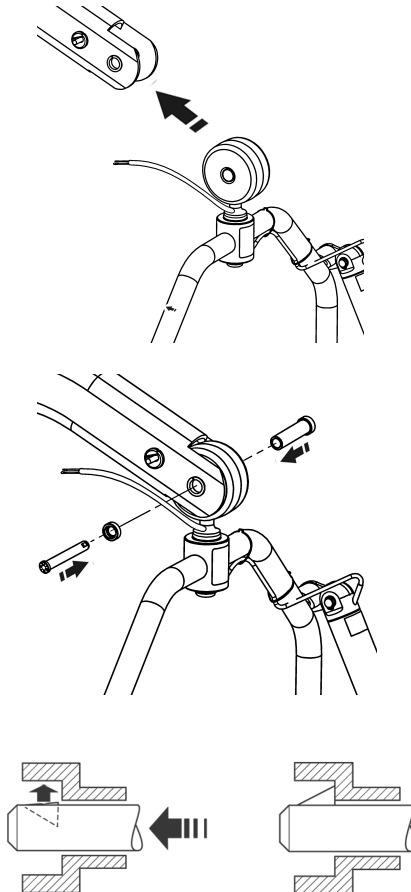

## CONNECTION

### To make the electrical connection:

Ensure the battery is disconnected and the control box is powered off.

1. Remove the cable grip from the boom using a small flat blade screw driver.  
Find and pull through the ends of the wires through the hole in the side of the boom.
2. Connect the bullet terminals on the ends of the wires to the bullet terminals on the end of the wires from the Integrated APC.
3. Fit the cable grip around the cable 150mm from the point the cable enters the cradle connection pin.
4. Feed any excess wire, including the bullet terminals, through the hole and into the boom.
5. Fit the cable grip back into the hole in the boom, ensuring it is pressed all the way in.
6. Check there is still 150mm of free cable length between the boom and the Integrated APC.

1

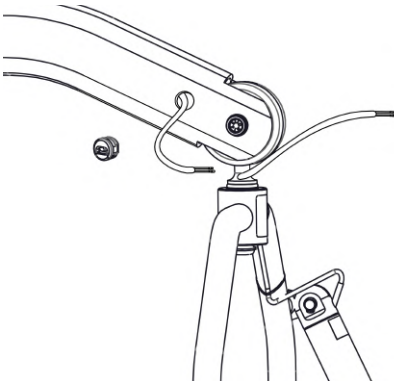

2

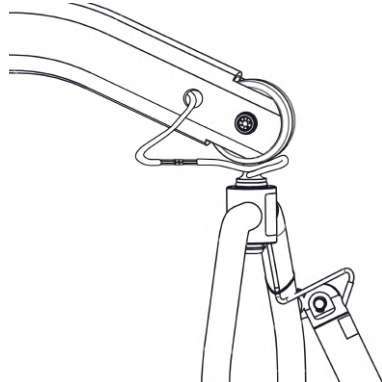

3

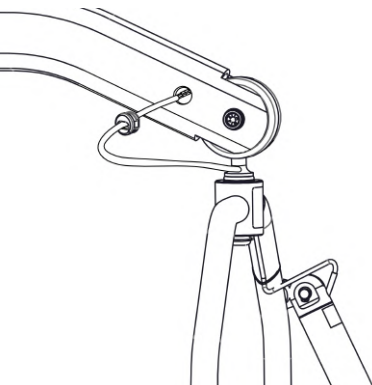

5

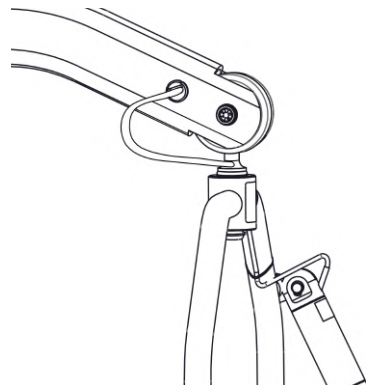



## DISASSEMBLY

The lift should not be disassembled unless for service, repair or transport if necessary. If disassembly is required, simply follow the assembly instructions in reverse sequence.

## ALWAYS CHECK THE FOLLOWING BEFORE OPERATION

- The mast is fully locked into position.

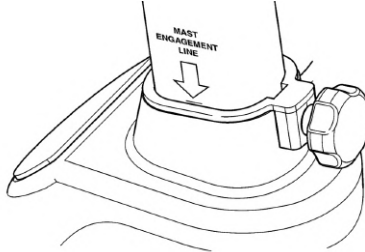

- The legs of the lift open and close satisfactorily (This is done via the hand control).

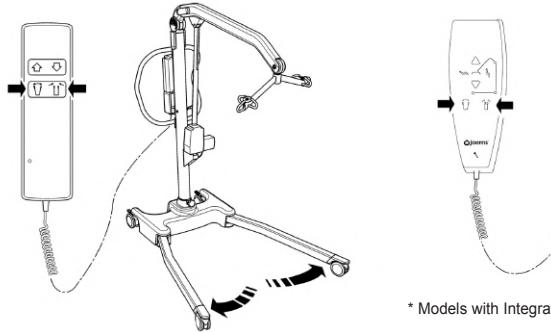

\* Models with Integrated APC.

- The red emergency stop button, located on the rear of the control box, is in the OFF (out) position.

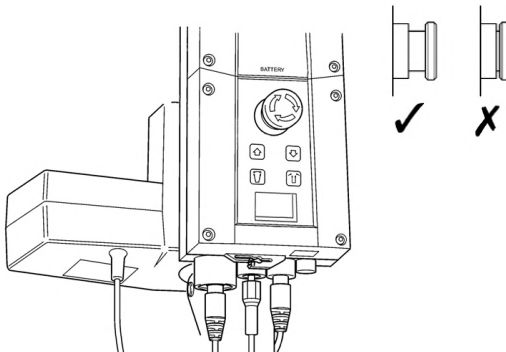

- Push the up and down buttons on the hand control and confirm the boom rises and lowers.

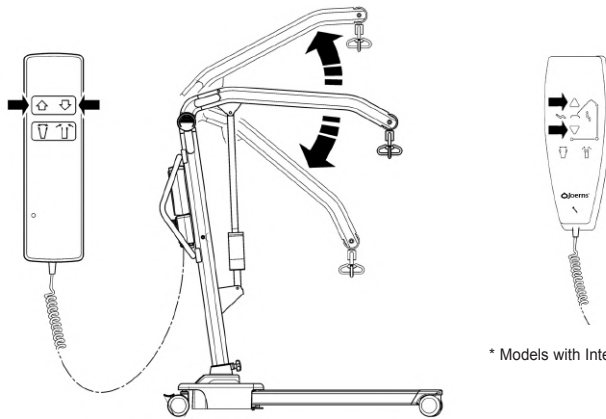

- On models with Integrated APC, push the seated person buttons on the hand control and confirm the cradle re-positions accordingly.

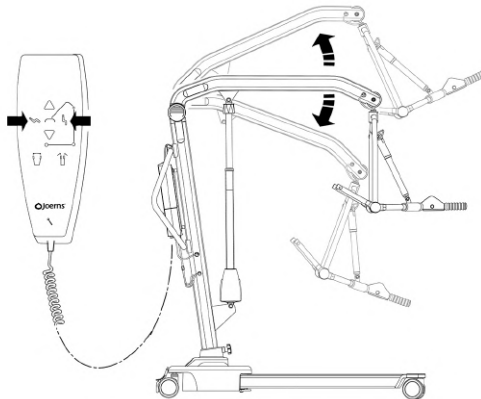

## 4. Safety Precautions

Please read and follow the safety precautions listed below. The operation and use of Oxford patient lifts is simple and straightforward. Following these few basic safety precautions will make lifting operations easy and trouble free.

### **READ AND UNDERSTAND THE USER INSTRUCTION MANUAL BEFORE USING THE OXFORD PRESENCE LIFT**

**WARNING:** Important safety information for hazards that might cause serious injury.

**CAUTION:** Information for preventing damage to the product.

**NOTE:** Information to which you should pay special attention.

### **WARNING**

- **ALWAYS** plan your lifting operations before commencing.
- **ALWAYS** carry out the **DAILY CHECK LIST** (later in this manual) before using the lift.
- **ALWAYS** familiarise yourself with the operating control and safety features of a lift before lifting a patient.
- **DO NOT** use a sling unless it is recommended for use with the lift.
- **ALWAYS** check the sling is suitable for the particular patient and is of the correct size and capacity.
- **NEVER** use a sling, which is frayed or damaged.
- **ALWAYS** fit the sling according to the instructions provided (user instructions).
- **ALWAYS** check the safe working load of the lift is suitable for the weight of the patient.
- **ALWAYS** carry out lifting operations according to the instructions in the user manual.
- **NEVER** disconnect or bypass a control or safety feature because it seems easier to operate the lift.
- **DO NOT** lift a patient with the castor brakes on. Always let the lift find the correct centre of gravity.
- **DO NOT** attempt to manoeuvre the lift by pushing on the mast, boom or patient.
- **ALWAYS** manoeuvre the lift with the handle provided.
- **ALWAYS** lower the patient to the lowest comfortable position before transfers.
- **DO NOT** push a loaded lift at speeds, which exceed a slow walking pace (3 Kilometers/hour 0.8 meters/second).
- **DO NOT** push the lift over uneven or rough ground, particularly if loaded.
- **DO NOT** attempt to push/pull a loaded lift over a floor obstruction, which the castors are unable to ride over.
- **NEVER** force an operating/safety control. All controls are easy to use and do not require excessive force.
- The **MINIMUM** load required to manually lower the hoist using the mechanical emergency down function is 30 kg.
- **DO NOT** park a loaded lift on **ANY** sloping surface.

- **DO NOT** use electric lifts in a shower.
- **DO NOT** charge an electric lift in a bathroom or shower room.
- **DO NOT** lift a patient unless you are trained and competent to do so.
- **YOUR** lift is for patient lifting. **DO NOT** use it, or allow it to be used, for any other purpose.
- **DO NOT** bump the lift down steps, loaded or unloaded.
- **DO NOT** attempt to negotiate a loaded lift on a slope, which exceeds 1:12 (approximately 5 degrees).
- **DO NOT** attempt to negotiate a slope without a second helper being present.
- **ALWAYS** check the hoist is not charging before moving as the electrical connection may be damaged.

## 5. Smart Monitor & Handset

### Standard Presence

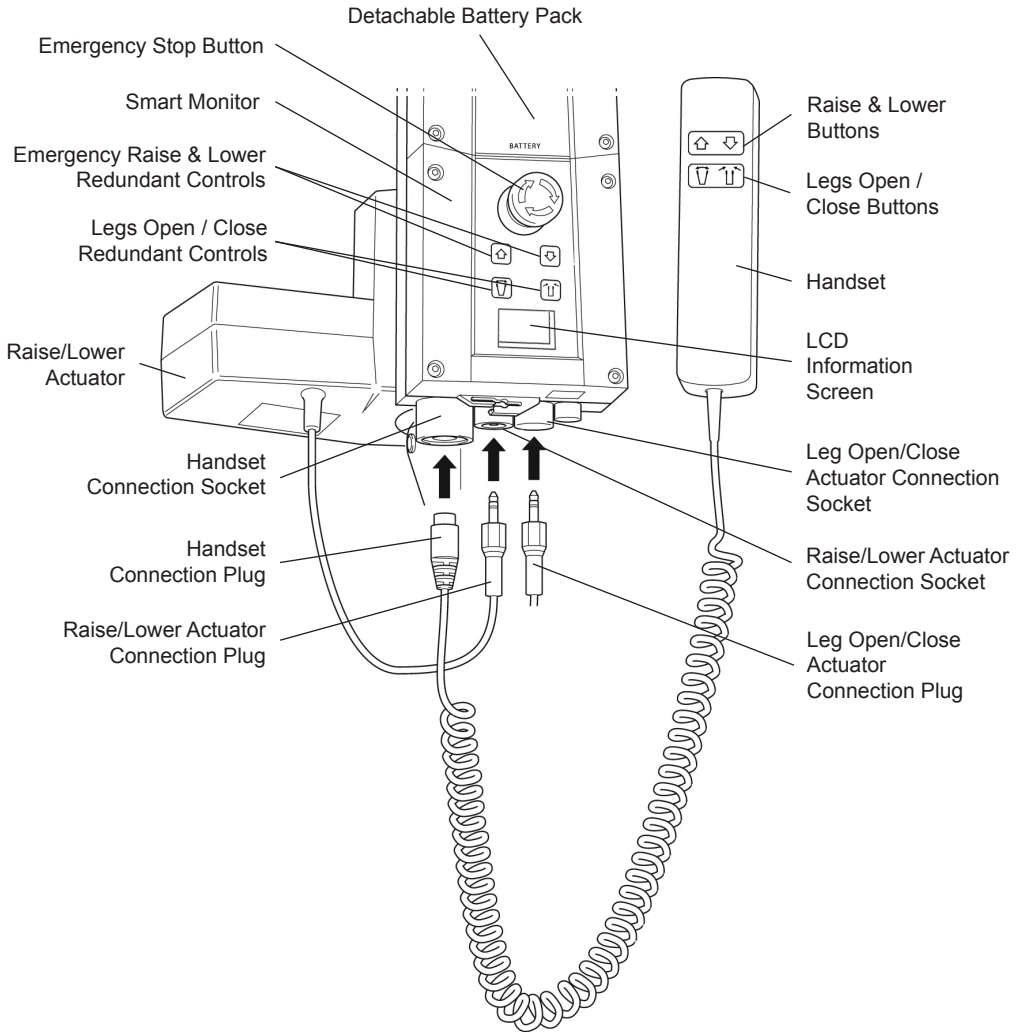

## Presence Fitted with Integrated APC

On models with Integrated APC, the handset and actuator cable connects will connect as follows:

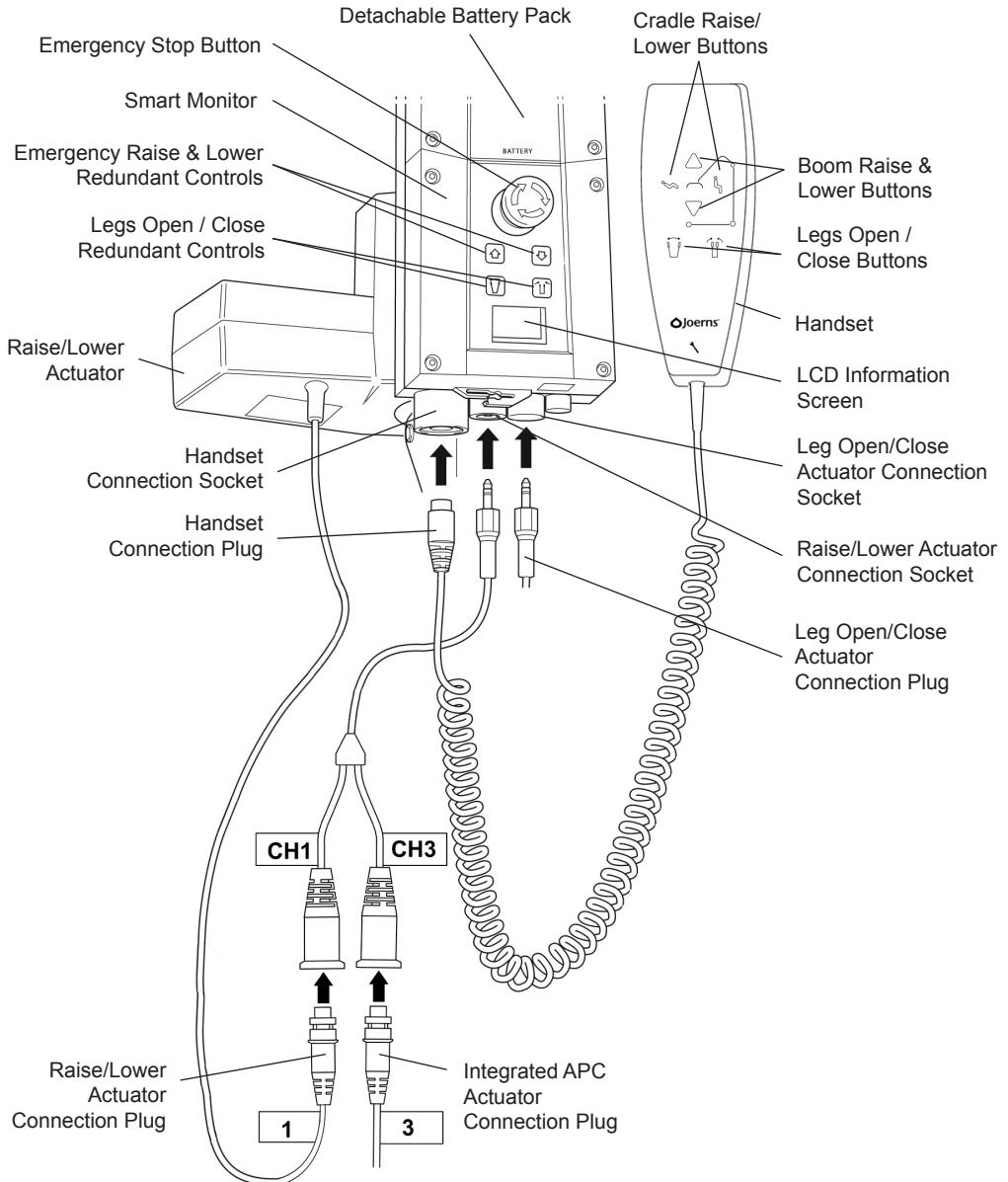

## Intended Use

The Oxford Smart Monitor is a control system for Oxford Hoists. The Smart Monitor stores useful servicing information about the hoist that can be recalled when required. This servicing information includes:

- Number of patient lift cycles
- Total work done by actuator
- Number of lift overloads (attempted lifts above the safe working load)
- Number of days since last service interval

The Oxford Smart Monitor contains a microprocessor inside making it possible to read out service data via the on-board LCD screen.

## Features

- Data collection in the control box with data display via LCD screen
- Work counter
- Intelligent cycle counter
- Service indicator
- Service interval indicator
- Overload information
- 3 step battery indicator





## Benefits

- Improved safety for both patient and carer
- Accurate service data available at the touch of a button
- Optimised product life time
- Ease of maintenance for engineers and service technicians

## LCD Display Screen

The Oxford Smart Monitor has the option to read out information via the LCD display screen. It is possible to read out total lifting cycles, total work done, overloads and number of days since last service, which can be used to quickly and easily evaluate the condition of the lift actuator.

This information is accessed by a ½ second press on the 'UP' button on the User handset or redundant 'UP' button on the Smart Monitor.

	12034	— Total Lifting Cycles
	1257000	— Total Work Done (Amps * Seconds)
	7	— Number of Overloads
	90/180	— Number of Days (since last service) / Number of Days (between services)

## Service & Usage Information



When it is time for a service, the service symbol will appear on the display. In addition, when the user handset is activated, the Smart Monitor will give an audible signal giving notice to users that a service is required.

The service symbol will be displayed each time the raise or lower keys are depressed on the User handset. When the service symbol is displayed, contact your authorised service provider immediately to arrange a service.

You may continue to use your lift for a short period of time until a service has been carried out.



If the lift stops because of an overload (an attempt to lift more than the safe working load) the overload symbol will appear on the LCD display and the lift will cease to operate until the additional load (above the SWL) has been removed.

### WARNING

**If the LCD display screen on your Smart Monitor has recorded an overload, Joerns Healthcare recommend that ALL routine daily checks are carried out on the lift prior to further use (for a list of daily checks, please refer to your lift user manual). Joerns Healthcare also recommend that you contact your authorised Oxford service provider for additional guidance.**



## On-Board Redundant Controls

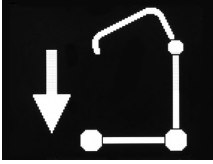

On-board redundant controls enable the lift to be raised or lowered in the event of an emergency.



If your lift incorporates powered leg positioning, there are redundant controls to both open and close the legs.

## Battery Information

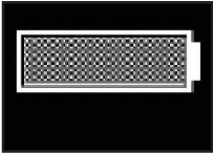

The display showing full battery means that the battery is fully charged and the lift is ready for use.

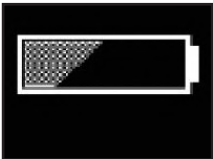

The display showing a half empty battery indicates that it is time to charge the battery.

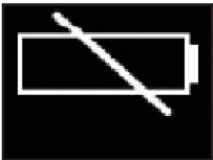

The empty battery symbol showing on the display indicates that the battery has no capacity left and should be placed on charge immediately.

### **⚠ WARNING**

To avoid possible permanent damage to the battery, the battery should be placed on charge as soon as the display indicates the half empty battery symbol.

## 6. Operating Instructions

### 1. Leg adjustment

The legs on the Oxford Presence are electrically adjustable for width. The legs can be opened to enable access around armchairs or wheelchairs. For transferring and negotiating narrow doorways and passages the lift legs should be in the closed position.

Electric leg adjustment - is achieved by pressing the appropriate buttons on the hand control. The legs will be locked whenever the hand control switch is released.

### 2. Castors and Braking

The lift has two braked castors which can be applied for parking. When lifting, the castors should be left free and un-braked. The lift will then be able to move to the centre of gravity of the lift. If the brakes are applied it is the patient that will swing to the centre of gravity and this may prove disconcerting and uncomfortable.

### 3. Raising and lowering the boom

The movement of the boom is achieved by a powerful electric actuator, which is controlled by a simple hand control unit. The hand control has two buttons with directional arrows UP and DOWN. The actuator stops automatically at the limit of travel in both directions. The hand control plugs into a socket at the base of the control box. There is a hook on the rear of the hand control, which allows it to be "parked" on the mast or boom when not in use.

### 4. Repositioning the Integrated APC (Only available on selected models)

For models with Integrated APC, the electric actuator on the cradle can be adjusted using the hand control. The hand control has two buttons depicting a seated person in two different degrees of tilt. Use these buttons to move the cradle. The actuator stops automatically at the limit of travel in both directions. The cradle position will be locked whenever the hand control is released.

### 5. Emergency Stop

The red Emergency Stop Button is located on the front of the control box and is activated by pressing in. This will cut all power to the lift and only be reset by twisting the button anticlockwise and releasing.

### 6. Redundant controls

All Oxford lifts are fitted with raise and lower buttons on the control box. These are located underneath the emergency stop button and can be used to lower/raise the patient should the hand control fail.

### 7. Mechanical Emergency Down

In the case of a complete electrical failure the electrical actuator is fitted with a spring loaded mechanical lowering device (RED BOSS). This will only operate when the lift is under load. The device must be twisted by hand and released to activate. A slow decent will commence. Repeat this process until the patient has been safely lowered.

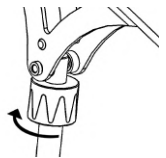

## **⚠ WARNING**

If this feature is used, the lift **MUST** be subsequently checked out by a competent engineer.

### 8. Batteries

The batteries are protected from deep discharge by a LOW VOLTAGE ALARM. This will sound when the batteries need recharging and the hand control is being operated. It will not sound independently of the hand control being operated. CAUTION: DO NOT IGNORE THIS WARNING ALARM. Complete the lifting operation and place the lift on charge (see charging instructions).

## **⚠ WARNING**

To avoid possible permanent damage to the battery, the battery should be placed on charge as soon as the display indicates the half empty battery symbol.

## 9. Slings

The Oxford Presence has the option of both a 6-point spreader bar and a 4-point positioning cradle. Both systems use different attachment methods and slings.

The 6-point system uses slings with webbing loops, which allow positioning adjustment by selecting different coloured loops. The 4-point cradle uses the Securi3 safety clip system and adjustment is made by rotating the 4-point cradle either upward or down.

**Loop strap slings:** Oxford Quickfit, Full Back, Quickfit Deluxe, Long Seat, Access and Silkfit

**Safety clip slings:** Oxford Comfort

The 6-point system attaches to the spreader bar hooks via loop straps (shown below), each sling is supplied with instructions. Please study the instruction guide before use.

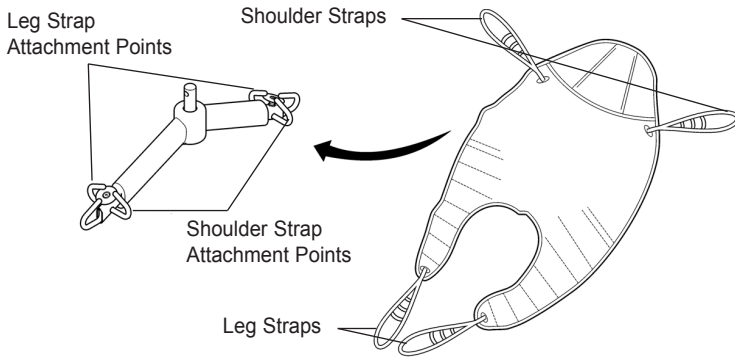

**6-point spreader bar.** Example of 6-point spreader bar sling with loop attachments.

The four point cradle sling attaches to the cradle studs via a safety clip system (shown below), each sling is supplied with instructions. Please study the instruction guide before use

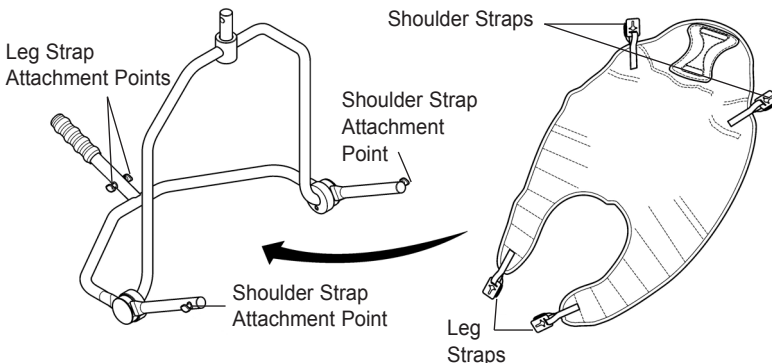

**4-point positioning cradle.**

Example of 4-point cradle sling with safety clip system.

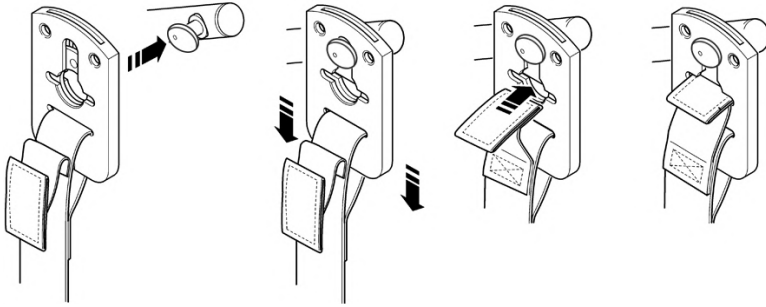

**Securi3 sling attachment system.** Example of installation.

**NOTE:** For detailed fitting instructions, please refer to the user guide supplied with each sling.

### **⚠ WARNING**

Joerns Healthcare recommends that slings be checked regularly and particularly before use for signs of fraying or damage. **DO NOT** use slings that are worn or damaged.

### **⚠ WARNING**

**OXFORD RECOMMENDS THE USE OF GENUINE OXFORD PARTS.** Oxford sling and lift products are designed to be compatible with one another. For country specific guidance on sling use and compatibility, please refer to the sling label or contact your local market distributor or Joerns Healthcare.

### **⚠ WARNING**

Refer to maximum weight capacity of lift. Sling capacity is limited by the maximum capacity of the lift.

## 7. Removal of Spreader Bar/Cradle Systems

**FOLLOW THESE INSTRUCTIONS EXACTLY**

### **⚠ WARNING**

If your Oxford Presence is fitted with an Integrated APC, please **DO NOT** attempt to remove it. The power cord will not allow effective removal and damage to the lift may occur.

Your Presence lift has the option of using both a 6-point spreader bar and 4-point positioning cradle. The removal of either of these systems is completed easily by the use of a quick-release pin. This is done quickly and easily, but you must read the following safety instructions to ensure the spreader bar/cradle is safely locked into position before use.

### **CONNECTION**

To connect, raise the spreader bar/cradle up toward the boom aperture.

Insert the pin sleeve through the plastic end cap and to support the spreader bar/cradle.

Once aligned in the boom slot reinsert the quick release pin fully into the sleeve until it locks into position. **YOU MUST CHECK THAT THE PIN IS SECURELY FITTED.**

To do this, press your finger into the barbed end. If the pin remains stationary the lift is safe to use.

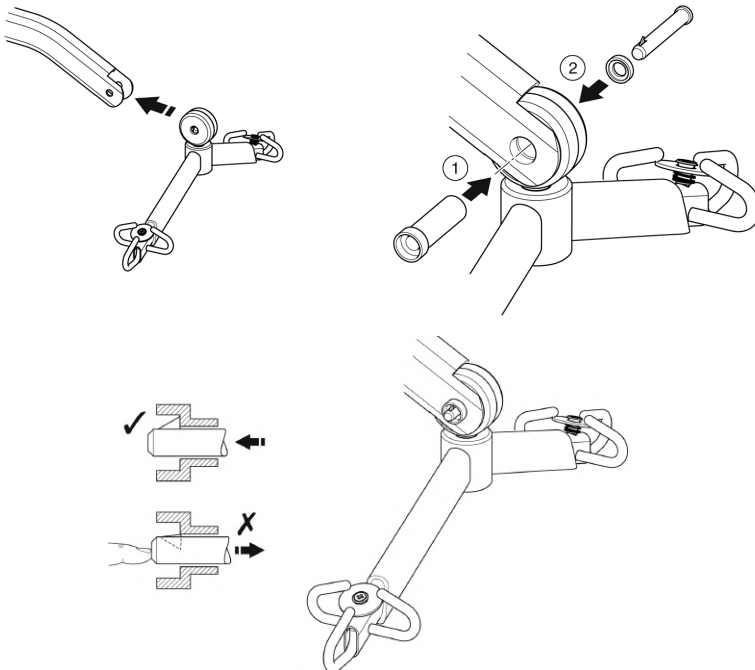

## REMOVAL

### ⚠ WARNING

If your Oxford Presence is fitted with an Integrated APC, please **DO NOT** attempt to remove it. The power cord will not allow effective removal and damage to the lift may occur.

**CAUTION:** Be sure to support the weight of the spreader bar/cradle before removing pin.

To detach pin, depress the spring barb (using a flat blade electrical screw driver or similar) and pull the pin out.

Support the spreader bar/cradle, and then pull the pin sleeve in the opposite direction, removing it completely from the boom. This will release the spreader bar completely.

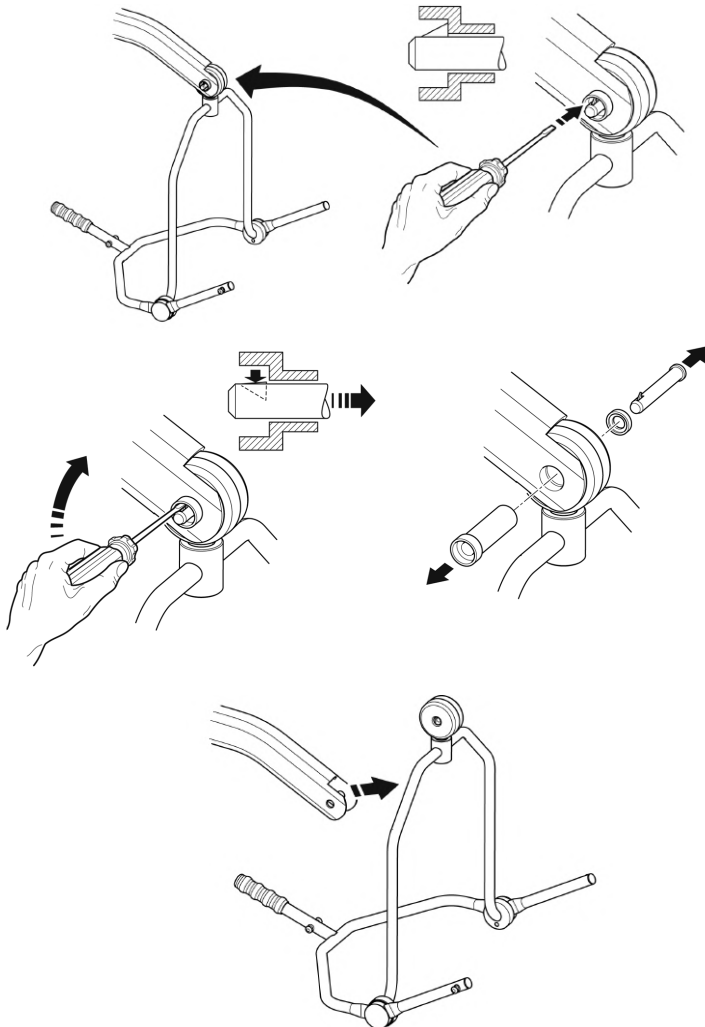

## 8. Charging Instructions

When the power pack needs charging it is removed from the lift and fitted to an off board charging unit.

Joerns Healthcare recommend an additional battery pack is purchased, so that one pack can be on charge at all times.

1. Remove the power pack from the lift. The pack is retained by a simple latch at the top of the power pack. Lift the latch and the power pack will be released.
2. Fit the power pack to the charging unit. The location and latching of the power pack to the charger is the same system as used on the lift.
3. Plug the charger mains plug into a suitable mains outlet and switch the mains supply ON.
4. Charging is automatic and will fully charge the batteries over a period of four (4) hours.

**Note:** Even if the charger is left plugged in for extended periods it will not allow the batteries to overcharge.

- a) Green Light - Indicates main power is on.
- b) Yellow Light - Indicates battery is charging.
- c) Battery will be fully charged when yellow light goes off.

**Note:** It is recommended that the battery be charged immediately upon receipt.

5. To return the lift to service, switch OFF the mains supply and remove the power pack from the charger. Fit the power pack to the lift and make sure the latch holding the pack in place is fully engaged. "Click" in place. The charging of Oxford electric lifts is simple and straightforward, but it is important to follow the charging instructions closely. Please pay particular attention to the following points, they will help you avoid problems with discharged batteries.

### WARNING

- **The battery, charger, hand control and control box are NOT to be opened by unauthorised personnel. (Contact your distributor for warranty and repairs).**
- **DO NOT touch battery/charger terminals.**
- **KEEP the batteries fully charged. Place the battery on charge whenever it is not in use. If it is more convenient to do so, place on charge every night. The charger will not allow the batteries to overcharge.**
- **NEVER run the batteries completely flat. As soon as the audible warning sounds, complete the lifting operation in hand and place on charge.**
- **To avoid possible permanent damage to the battery, the battery should be placed on charge as soon as the display indicates the half empty battery symbol.**
- **NEVER store the battery for long periods without regular charging throughout the storage period.**
- **ALWAYS make sure the mains power to the charger is switched off before connecting or disconnecting the battery pack.**
- **NEVER leave the battery pack connected with the charger mains power switched off.**
- **DO NOT leave the charger switched on with the battery disconnected.**
- **DO NOT use the lift while charging is taking place.**

- **CHECK** the lift is not charging before moving as the electrical connection may be damaged.
- **NEVER** disconnect the charger plug by pulling on the cable.
- **BE CAREFUL** not to trip over the charge lead.
- **DO NOT** charge an electric lift in a bathroom or shower room.



## 9. Maintenance Schedule

All Oxford products are designed for minimum maintenance, however some safety checks and procedures are required. A schedule of DAILY tasks are detailed below. Daily checks and a six monthly service, inspection and test will ensure a lift is kept in optimum safe working condition. A list of spare parts is available upon request.

The LOAD TEST and certification should only be carried out by qualified personnel or an authorised service agent / dealer.

DAILY CHECK LIST: Joerns Healthcare strongly recommends the following checks be carried out on a daily basis and before using lift.

- MAKE sure the lift moves freely on its castors.
- MAKE sure the spreader bar is free to rotate and swing. Check the spreader bar is firmly attached to the boom.
- ENSURE the mast is fully engaged into the mast slot and the mast locking device is securely tightened.
- EXAMINE the sling hooks on the spreader bar and side suspenders for excessive wear. If in doubt - do not use.
- EXAMINE slings for fraying or other damage. DO NOT use any sling if damaged or if the sling shows signs of wear.
- MAKE sure the legs open and close correctly.
- OPERATE the hand control to confirm the boom raises and lowers satisfactorily.
- OPERATE the hand control to confirm the integrated powered positioning cradle is operational (Model specific)
- CONFIRM the lift is not giving a low battery alarm when the hand control is operated. If the alarm sounds DO NOT use and place on charge immediately.
- Check the operation of the emergency stop button.

### MAINTENANCE, INSPECTION AND TEST

Joerns Healthcare recommend a thorough inspection and test of the Oxford Presence lift and lifting accessories, slings, scales etc is carried out on a regular basis. Inspection frequency varies depending on locality, so you must check with your dealer or local government agency as appropriate regarding how often an inspection is required. The examination and test should be conducted according to the recommendations and procedures provided in this manual. Joerns Healthcare recommends maintenance, inspection and certified testing is carried out by authorised service agent / dealers only.

**NOTE:** These recommendations are in compliance with the requirements of 1998 No2307 Health and Safety: The Lifting Operations and Lifting Equipment Regulations 1998. This is a UK regulation. Outside the UK please check your local country requirement.

**\*THESE CHECKS SHOULD INCLUDE:**

	Initially	Before Use	Service Intervals
<b>1. SPREADER BAR:</b> Check the spreader bar for freedom of rotation and swing. Check for wear on the central pivot. Check for firm attachment to the boom.	✓	✓	✓
<b>2. BOOM:</b> Check the attachment of the boom to the mast. Make sure there is only minimal side movement of the boom and the boom is free to rotate on the boom bearing.	✓	✓	✓
<b>3. MAST:</b> Check the operation of the mast-locking device. Make sure the mast fully engages into the socket. Check the bottom actuator.	✓	✓	✓
<b>4. ACTUATOR:</b> The actuator should require no maintenance other than checking for correct operation and listening for unusual noise.			✓
<b>5. SMART MONITOR:</b> Check the function of the emergency stop button. Inspect the hand control socket for correct fitting. Check functioning of the hand control. Check the redundant controls and confirm they operate as intended.	✓	✓	✓
<b>6. BATTERIES:</b> The batteries are housed in the power pack and should not require maintenance other than the regular charging as detailed in the charging instructions. Check that the connections remain clean.			✓
<b>7. LEG ADJUSTMENT:</b> Check the legs operate in both full extensions (inward/outward).	✓	✓	✓
<b>8. CASTORS:</b> Check all castors for firm attachment to the legs. Check for free rotation of the castor and the wheels.	✓	✓	✓
<b>9. CLEANING:</b> Clean with ordinary soap and water and/or any hard surface disinfectant. Harsh chemical cleaners or abrasives should be avoided as these may damage the surface finish of the lift. Avoid wetting any of the electrical parts.		✓	✓
<b>10. LOAD TEST:</b> The load test should be carried out in accordance with the manufacturer's test procedures. It is strongly recommended the testing is carried out by an authorised service dealer.			✓
<b>11. BASE AND WHEELS:</b> Ensure base is even and level (all four wheels are on the floor).	✓	✓	✓
<b>12. SLINGS:</b> Check for wear and fraying.	✓	✓	✓
<b>13. LUBRICATION:</b> Oil pivot joints, including mast and boom connections, pedal assembly, spreader bar joint (only if required).			✓
<b>14. HAND SET:</b> Ensure plugged fully into controller.	✓	✓	
<b>15. QUICK RELEASE PIN:</b> Ensure the pin is securely fitted before lifting, by pressing the barbed end.	✓	✓	
<b>16. FIXINGS:</b> Check all nuts, bolts, screws and fasteners for excessive wear and for tightness. Replace as required.			✓
<b>17. INTEGRATED APC:</b> (Model specific). Check the Integrated APC operates in both directions via the hand control. The actuator should require no maintenance other than checking for correct operation and listening for unusual noise.	✓	✓	✓

## 10. Technical Specifications

Safe Working Load .....	500 lbs.....	227 kgs
Maximum Overall Length .....	57.5 inches.....	1460 mm
Minimum Overall Length .....	55.1 inches.....	1400 mm
Maximum Overall Height.....	81.3 inches.....	2065 mm
Minimum Overall Height.....	57.5 inches.....	1460 mm
Spreader Bar Maximum Height .....	75.2 inches.....	1910 mm
Spreader Bar Minimum Height.....	16.9 inches.....	430 mm
Height at Maximum Reach.....	51.5 inches.....	1310 mm
Reach at Maximum Height.....	25.6 inches.....	650 mm
Reach at Minimum Height.....	15.7 inches.....	400 mm
Maximum Reach* .....	36.6 inches.....	930 mm
Turning Radius .....	64.2 inches.....	1630 mm
Legs Open - External Width .....	45.2 inches.....	1150 mm
Legs Open - Internal Width .....	40.1 inches.....	1020 mm
Legs Closed - External Width .....	26.4 inches.....	670 mm
Legs Closed - Internal Width .....	21.6 inches.....	550 mm
Overall Height of Legs.....	4.7 inches.....	120 mm
Ground Clearance.....	1.4 inches.....	35 mm
Front Twin Castors.....	4 inches.....	100 mm
Rear Braked Castors.....	4 inches.....	100 mm

\* Reach = centre of spreader bar to the front of the mast

### 4-point Positioning Cradle (measurement to top of location pins)

Cradle Max. Height.....	61 inches.....	1550 mm
Cradle Min. Height (usable) .....	15.4 inches.....	390 mm

### Weights

Mast, Base & Boom Assembly.....	81.4 lbs.....	37 kgs
(includes 2 point spreader bar)		
Mast, Base & Boom Assembly.....	101.4 lbs.....	46 kgs
(with Integrated APC)		
Power Pack .....	6.6 lbs.....	3 kgs
Total.....	88 lbs.....	40 kgs
Base Assembly (not inc battery) .....	44 lbs.....	20 kgs
Mast & Boom (not inc battery) .....	37.4 lbs.....	17 kgs
4-point Positioning Cradle .....	13.2 lbs.....	6 kgs

All measurements are within a +5/-5 degree of tolerance.

**ELECTRICAL SPECIFICATIONS:**

BATTERIES.....	24 volt Rechargeable sealed lead acid type
BATTERY CAPACITY.....	3.2 Ampere hours
CHARGER RATED INPUT.....	100 - 240 V AC/ 50/60 Hz
CHARGER RATED OUTPUT.....	29.5 VDC, Max. 19 W

**ELECTRIC SHOCK PROTECTION**

CHARGER.....	CLASS II (EN 60601-1)
LIFT.....	INTERNAL POWER SOURCE

**DEGREE OF SHOCK PROTECTION**

CHARGER.....	TYPE B (EN 60601-1)
LIFT.....	TYPE B (EN 60601-1)

**ENVIRONMENTAL CONDITIONS:**

Outside this environment functionality and safety may be compromised.

**OPERATING:**

TEMPERATURE.....	5°C to 40°C
RELATIVE HUMIDITY.....	20% to 90% @ 30°C - not condensing
ATMOSPHERIC PRESSURE.....	700 to 1060 hPa

**STORAGE:**

TEMPERATURE.....	-10°C to +50°C
RELATIVE HUMIDITY.....	20% to 90% @ 30°C - not condensing
ATMOSPHERIC PRESSURE.....	700 to 1060 hPa

**IP RATINGS**

CONTROL BOX.....	IPX4
ACTUATOR.....	IPX4
OFF BOARD CHARGER.....	IPX5
BATTERY.....	IPX5
HANDSET.....	IPX5

**DUTY CYCLES**

ACTUATOR.....	10% (2 min./18 min.)
CHARGER.....	Approx. 4 hrs.

**ACOUSTICS**

A-Weighted sound power level.....	60 dB (A)
-----------------------------------	-----------

**KEY SYMBOLS:**

The following symbols are used on the charger, control unit and battery:



Type B equipment, as per EN 60601-1



Class 2 equipment



The disposal of the charging and control unit should not be mixed with general household waste.

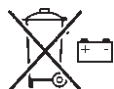

The disposal of batteries should not be mixed with general household waste.



The disposal of electronics should not be mixed with general household waste.



For indoor use



ATTENTION, consult accompanying documents.

**WEEE Producers registration number WEE/GG0464RZ**

## 11. Warranty

Joerns Healthcare has an established network of authorised distributors and service agents who will be pleased to handle all of your purchasing, warranty, repair and maintenance enquiries. It is recommended that our products are commissioned by your authorised distributor or service agent.

The distributor or service agent operates the warranty programme, so it is important to keep a record of their name, address and telephone number so they can be contacted should any problem arise. If you are in any doubt as to where your lift was purchased, Joerns Healthcare can trace the supplier if you quote the serial number of the lift.

All warranty claims are subject to the correct use and maintenance in accordance with the user instruction manual provided with each lift. Damage caused by use in unsuitable environmental conditions or failure to maintain the product in accordance with user and service instructions is not covered. Your statutory rights remain unaffected.

**REMEMBER:** Contact your authorised distributor or service agent for purchases, repairs, servicing and certified maintenance.

Your distributor:

### **EVOCARE AUSTRALIA PTY LIMITED**

A.B.N. 98 078 566 604

Trading as **EVOCARE** and **L&M EQUIPMENT**

P.O. Box 1144, Stafford Qld. 4053

Ph: 07 3355 8000 Fax: 07 3355 5043

Website: <http://www.evocare.com.au>

Email: [sales@evocare.com.au](mailto:sales@evocare.com.au)

[workshop@evocare.com.au](mailto:workshop@evocare.com.au)

[warehouse@evocare.com.au](mailto:warehouse@evocare.com.au)

[accounts@evocare.com.au](mailto:accounts@evocare.com.au)





